

DIMENSION DRAWING - SLIP RING MOTOR (FRAME 132 TO 160) IM 1002/1001

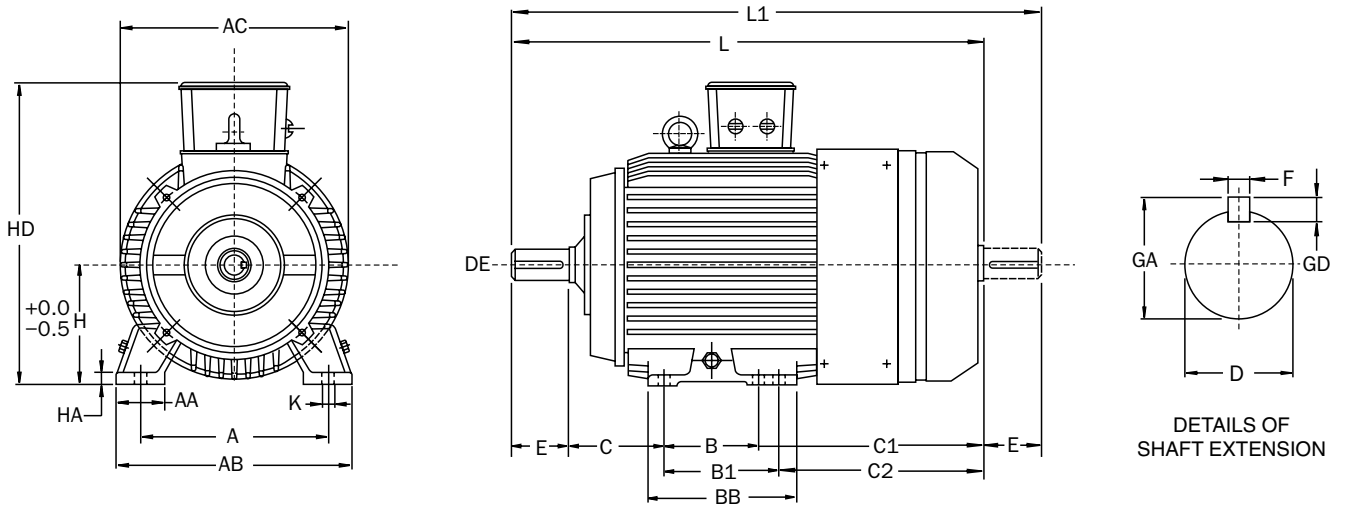

Note :
Mounting dimensions are as per IS : 1231

FRAME	A	B	B1	C	C1	C2	Ø D	E	F	H	K	L	L1	AA	AB	AC	BB	HA	HD	GA	GD	Net Wt	Gross Wt	Shipping Dimn. (L x b x h)
ID 132M	216	—	178	89	—	288	38 K6	80	10	132	12	635	715	40	256	264	218	12	320	41	8	90	140	560 X 365 X 315
ID 160M	254	210	—	108	330	—	42 K6	110	12	160	15	765	868	60	314	318	270	14	410	45	8	145	177	690 X 460 X 440
ID 160L	254	254	—	108	330	—	42 K6	110	12	160	15	810	912	60	314	318	314	14	410	45	8	170	202	690 X 460 X 440